



Faculty of Medicine
School of Medical Sciences

PATH3207

Musculoskeletal Disease

COURSE OUTLINE

SEMESTER 2, 2018

CRICOS Provider Code 00098G

Musculoskeletal Diseases Manual

PATH3207

2018

Preface

This is the 14th edition of the manual for Musculoskeletal Diseases produced by the staff of the Department of Pathology at the University of New South Wales. It contains a large amount of relevant information regarding the course PATH3207 Musculoskeletal Diseases.

We recognise that this manual might contain some errors and may need further improvements in the future. Therefore, we welcome comments from staff and students and seek your co-operation in identifying errors of content or style, so that they may be corrected in subsequent editions.

**Author and Editor:
A/Prof Nicodemus Tedla**

Department of Pathology Student Manual: Musculoskeletal Diseases ISBN 0-7334221-9-5

© 2002-2018 Department of Pathology, University of New South Wales, Sydney 2052 Australia

Table of Contents

Preface	i
Introduction	1
Official Communication by email	2
Course Outline	3
Campus Based Course staff	3
Course Administration	3
Student Support Service	3
Course Details	3
Course Objectives	4
Student Learning Outcomes	4
Graduate Attributes	4
Rationale for the Inclusion of Content and Teaching Approach	4
Teaching Strategies	4
Recommended Text	5
Research Opportunities	5
Course Evaluation and Development	5
Course Schedule	6
Lecture Program Outline	8
Guide to Practical Classes	10
A simple guide to description of macroscopic specimens (“pots”)	10
A simple guide to writing histopathological descriptions	11
Team-based learning	13
Evidence based symposium	14
Format for Evidence Based Symposium Written Abstract	14
Evidence Based Symposium assessment forms	15
Adaptive tutorials	18
Assessments	19
Sample Examination Paper	20
PART A (25 Marks)	20
PART B (20 marks)	20
Resources for Students	22

Additional Learning Resources	22
PATH 3207 Moodle course	22
Online lecture slides	22
PATH3207 Virtual slide box and Images	22
Images of Disease (IOD) database	23
Interactive images of disease	23
The Museum of Human Disease	23
Administrative Matters	25
Academic Honesty and Plagiarism	26
Student Equity and Disabilities Unit	27
Teaching Laboratories Risk Assessments	28

Introduction

We would like to warmly welcome third year science students to the **Musculoskeletal Diseases** course, offered in Session 2, 2018, by the Department of Pathology. The course covers bone and joint disease, neuromuscular disease, musculoskeletal trauma and orthopaedics.

This course will be beneficial to students wishing to pursue careers in the health sciences, especially medicine (in particular rehabilitation medicine), biomedical research or hospital-based laboratory work. A sound understanding of musculoskeletal pathology should provide an effective framework from which to approach diagnosis and management of common clinical scenarios that you may well encounter in your future careers.

Staff of the Department of Pathology joins me in wishing you an interesting and enjoyable session.

Nicodemus Tedla
A/Professor in Pathology – PATH3207 Course Convenor

Dr Karim Burkhardt
Lecturer in Pathology – PATH3207 Course Co-convenor

Please read this outline in conjunction with the following pages on the [School of Medical Sciences website](#)

- [Advice for Students](#)
- [Learning Resources](#)

(or see "STUDENTS" tab at medicalsciences.med.unsw.edu.au)

Official Communication by email

All students in course PATH3207 are advised that email is now the official means by which the School of Medical Sciences at UNSW will communicate with you. All email messages will be sent to your official UNSW email address (e.g., z1234567@student.unsw.edu.au) and, if you do not wish to use the University email system, you MUST arrange for your official mail to be forwarded to your chosen address. The University recommends that you check your mail at least every other day. Facilities for checking email are available in the School of Medical Sciences and in the University library. Further information and assistance is available from DIS-Connect, Tel 9385 1777. The UNSW Library runs free email courses.

Course Outline

Campus Based Course staff

Dr Ingvar Birznieks, Dr Karim Burkhardt, Professor Nick Di-Girolamo, Dr Patrick de Permentier, Dr Irina Dedova, Dr Cristan Herbert, Dr Chaturaka Rodrigo, A/Professor Andrew Moorhouse, A/Professor Nicodemus Tedla (Course convenor), A/Professor Patsie Polly, Professor Gary Velan

Course Administration

Administrative and general problems related to your attendance, or the content and conduct of the course, can in the first instance be addressed by consulting A/Prof Nicodemus Tedla by e-mail (n.tedla@unsw.edu.au) and in the second instance be addressed by consulting A/Prof Shane Thomas, Head of Teaching in the Department of Pathology (shane.thomas@unsw.edu.au) or Professor John Pimanda, Head of the Department of Pathology (jpimanda@unsw.edu.au). Students wishing to see their tutors or other members of staff should call in at the School office (ground floor) and make an appointment with the assistance of the staff.

Attendance is **mandatory** to all practical classes in this course and students are **highly advised to attend all lectures** as large proportions of the lectures are delivered by invited guest speakers who will not record their presentations due to issues of patient confidentiality and intellectual property. Students that fail to attend >90% of the tutorials and practical classes may not be allowed to complete the course.

Guidelines on extra-curricular activities affecting attendance are found at:

<https://medalsciences.med.unsw.edu.au/sites/default/files/Extra-curricularActivitiesSOMS.pdf>

If students have difficulties of a personal nature, they should contact the School's Grievance Officer, Prof Nick Di-Girolamo (n.digirolamo@unsw.edu.au) or Faculty's student wellbeing officer A/Professor Ute Conna Vollmer (ute@unsw.edu.au).

If a student(s) want to have a result reviewed (checking of marks and/or reassessment), they should formally apply through <https://my.unsw.edu.au/student/academiclife/assessment/Results.html>

To appeal academic standing or ability to progress visit

<https://my.unsw.edu.au/student/academiclife/assessment/academicstandinghowtoappeal.html>

Should you feel that there are particular circumstances that have affected your performance in the course you should lodge an application for special consideration. Special considerations sought outside the 3day rule will not be accepted except under TRULY exceptional circumstances. The procedures involved in this are outlined in the UNSW Student Guide, and special forms are widely available on campus e.g. Student Health Centre, Student Centre or at <https://student.unsw.edu.au/special-consideration>

Information on the different research units in the Department of Pathology and the research interests of each staff member is available at Department of Pathology's home page at <http://medalsciences.med.unsw.edu.au/>

Student Support Service

Those students who have a disability that requires some adjustment in their teaching or learning environment are encouraged to discuss their study needs with the course convener prior to, or at the commencement of, their course, or with the Equity Officer (Disability) in the Equity and Diversity Unit (9385 4734 or <https://student.unsw.edu.au/contact-seadu-disability-support>). Issues to be discussed may include access to materials, note-takers, the provision of services and additional exam and assessment arrangements. Early notification is essential to enable any necessary adjustments to be made.

Any student having trouble with the course should discuss this either with the Convenor of PATH3207 A/Prof Tedla, Head of Teaching A/Prof Shane Thomas or the Head of Department Prof John Pimanda.

Course Details

This course is offered during Session 2 and carries six units of credit. Successful completion of an introduction to basic diseases processes in second year (PATH 2201 or PATH 2202) and in basic Histology (ANAT 2511) and Anatomy (ANAT 2111, ANAT 1521 or ANAT 2241) are prerequisites for enrolment in the

course. Molecular basis of inflammation and infection in third year (PATH 3205) is highly recommended. Attendance at all tutorials, practical classes is mandatory.

Course Objectives

PATH3207 comprises teaching current concepts of musculoskeletal diseases including arthritis, metabolic bone diseases, neoplasms in bone, causes of musculoskeletal pain and limitations of movement and neuromuscular diseases as well as detailed coverage of fracture healing and its complications, multiple traumas, and current research on biomaterial and prosthetic devices relevant to joint, muscle and/or neuronal repairs.

Graduate Attributes

The students will be encouraged to develop the following Graduate Attributes by undertaking the selected activities and knowledge content. These attributes will be assessed within the prescribed assessment tasks. Please see the Assessment section for more details:

1. An in-depth engagement with the relevant disciplinary knowledge in its interdisciplinary context.
2. The capacity for analytical and critical thinking, as well as for creative problem solving
3. The ability to engage in independent, team-based and reflective learning
4. The skills of effective communication

Student Learning Outcomes

At the completion of this course you should be able to:

1. Describe and explain the molecular and cellular pathogenic mechanisms of musculoskeletal and neuromuscular diseases;
2. Describe the macroscopic and microscopic appearances of musculoskeletal and neuromuscular diseases;
3. Correlate the clinical features of musculoskeletal and neuromuscular diseases with the underlying pathological processes and mechanisms;
4. Describe the sensitivity, specificity, cost effectiveness and availability of laboratory and imaging investigations for the diagnosis of musculoskeletal diseases;
5. Discuss recent advances in biomedical, bioengineering, molecular and biological research related to the treatment of musculoskeletal and neuromuscular diseases;
6. Develop written and oral skills in scientific communication;
7. Develop skills in peer review and assessment of scientific research.

Rationale for the Inclusion of Content and Teaching Approach

The intended learning outcomes are achieved through study of the common patterns of response to injury, which are often referred to as pathological processes. In depth study of mechanisms and causes unique to the musculoskeletal system are highlighted in context of the general pathological processes. To understand these processes, you will draw on your knowledge of normal anatomy, histology, biochemistry, physiology, general pathology and biomedical engineering.

This course will be beneficial to students wishing to pursue careers in the health sciences, especially in clinical rehabilitation medicine, biomedical research or hospital-based laboratory work. A sound understanding of musculoskeletal pathology should provide an effective framework from which to approach diagnosis and management of common clinical scenarios that you may well encounter in your future careers.

Teaching Strategies

The course employs a variety of teaching modes in order to facilitate your learning:

1. A series of lectures introduce you to pathological processes, as well as specific examples of those processes affecting the musculoskeletal system. These lectures are given by invited and campus-based discipline experts.
2. Tutorials that are designed in a form of team-based collaborative learning that incorporate small group tutorials and a series of topical quizzes to be completed individually and as a team. It is anticipated that students will have an enhanced learning experience using team-based learning and peer teaching. The tutorials intended to extend and amplify your understanding of material presented in lectures in an interactive format, where you are given opportunities to seek clarification on any aspect of the topics covered, as well as to tackle concepts that might be difficult to grasp.

3. Practical classes that incorporate clinico-pathological correlation sessions are intended to allow you to apply your understanding of disease processes to microscopic and macroscopic appearances of disease in tissues (lesions), and to correlate these with the clinical manifestations. Computer-based virtual microscopy is utilised together with a variety of diagnostic imaging modalities and laboratory investigations to permit correlation between disease processes, changes in cells and tissues at the microscopic level and the clinical manifestations of disease.
4. Evidence based symposia based on cutting edge topics in musculoskeletal diseases that are organised, designed, delivered and assessed by students working in small groups.
5. A midsession written exam with group and individual feedback aimed at familiarising students with the end of the year practical and written exams and providing students with tailored feedback.
6. Two sessions of group discussion/feedback on homework tasks, the midsession exam and specific student questions.
7. Learning is supported via a Moodle module (accessible via student number and zPass at <https://moodle.telt.unsw.edu.au/>). Announcements, timetables, lecture slides and other resources will be made available during the course.
8. The PATH3207 Student Manual contains specific learning objectives for tutorials and practical classes, together with the course timetable and useful background information.

Recommended Text

You are expected to use the following text *Robbins Basic Pathology*, 10th edition. V. Kumar, A.K. Abbas, & J.C. Aster (2018); Saunders & Co. Philadelphia PA; Elsevier Saunders. The text is also available online by searching for Robbins Basic Pathology on the UNSW library home page.

Robbins and Cotran Pathologic Basis of Disease 9th edition. V. Kumar, A.K. Abbas & J.C. Aster (2013) Elsevier Saunders is recommended for students wishing to study the molecular biology or clinical features of diseases in greater depth. That text is also available via MD Consult.

Research Opportunities

Opportunities exist for all students wishing to undertake undergraduate and postgraduate research program within the School of Medical Sciences. Information can be accessed via the Faculty of Medicine directory for the School of Medical Sciences at: <https://medicallsciences.med.unsw.edu.au/research>

Students are also encouraged to communicate with invited guest lecturers that are active in research and clinical practice.

Course Evaluation and Development

Periodically student evaluative feedback on the course is gathered, using [myExperience](#) and an in-house course evaluation questionnaire. This questionnaire is included at the end of this manual to be completed by all students during Practical Class 11 to provide feedback on the course. Student feedbacks are highly valued, and continued improvements are made to the course based on such feedbacks.

Course Schedule

Week	Date	Time	Location	Lecturer	Title
1	24/7/2018	11	LG02	de Permentier	Lecture - Revision of Bone, Cartilage, and Joint Histology
	25/7/2018	12	LG02	Tedla	Lecture – Brief course overview and Pathological Basis of Bone/Joint pain and limitation of movement
	27/7/2018	13	WW G6/G7 WW G16/G17	Brettle/Feather/Kokkinos/ Goyette	Tutorial - Anatomy of Bone, Cartilage and Joint
	27/7/2018	14	WW G6/G7	Tedla/ Brettle/Feather/Kokkinos/ Goyette	Practical - Histology of Bone, Cartilage and Joint
2	31/7/2018	11	LG02	Tedla	Lecture - Causes of Fractures and Mechanisms of Fracture
	01/8/2018	12	LG02	Tedla	Lecture – Treatment approaches and Complications of Fractures
	03/8/2018	13	WW G6/G7 WW G16/G17	Brettle/Feather/Kokkinos/ Goyette	Tutorial - Fracture Healing and Complications
	03/8/2018	14	WW G6/G7	Tedla/ Brettle/Feather/Kokkinos/ Goyette	Practical - Histopathology of Fractures
3	07/8/2018	11	LG02	Tedla	Prelude to Evidence-Based Symposium
	08/8/2018	12	LG02	Rodrigo	Lecture - Differential diagnosis of back pain
	10/8/2018	13	WW G6/G7	Tedla/ Brettle/Feather/Kokkinos/ Goyette	Combined Tutorial and Practical – Causes of back pain
4	14/8/2018	11	LG02	Burkhardt	Lecture – Primary Bone Tumours
	15/8/2018	12	LG02	Burkhardt	Lecture - Metastatic Bone Tumours
	17/8/2018	13	WW G6/G7 WW G16/G17	Brettle/Feather/Kokkinos/ Goyette	Tutorial - Primary and Secondary Bone Tumours
	17/8/2018	14	WW G6/G7	Burkhardt / Brettle/Feather/Kokkinos/ Goyette	Practical - Histopathology of Bone Tumours
5	21/8/2018	11	LG02	Bryant	Lecture – Mono/Oligoarthropathies: Causes, Clinical & Diagnosis
	22/8/2018	12	LG02	O'Neill	Lecture - Polyarthropathies: Causes, Clinical manifestation &
	24/8/2018	13	WW G6/G7 WW G16/G17	Brettle/Feather/Kokkinos/ Goyette	Tutorial - Arthritis
	24/8/2018	14	WW G6/G7	Tedla/ Brettle/Feather/Kokkinos/ Goyette	Practical - Histopathology of Arthritis and Clinical Correlations
6	28/8/2018	11	LG02	Morris	Lecture - Diagnostic Imaging of Musculoskeletal Diseases*
	29/8/2018	12	LG02	McFarland	Lecture - New Approaches in Musculoskeletal Repair*
	31/8/2018	13	WW G6/G7		MIDSESSION EXAM
7	04/9/2018	11	LG02	Dedova	Lecture - Strains, Sprains and Dislocations
	05/9/2018	12	LG02	Duflou	Lecture - Forensic Pathology of Musculoskeletal System*
	07/9/2018	13	WW G6/G7 WW G16/G17	Brettle/Feather/Kokkinos/ Goyette	FEEDBACK – MIDSESSION EXAM
	07/9/2018	14	WW G6/G7	Tedla	Revision - Answer student questions on topics covered so far and review homework tasks

Week	Date	Time	Location	Lecturer	Title
8	11/9/2018	11	LG02	Weber	Lecture - Metabolic Bone Diseases
	12/9/2018	12	LG02	Moorhouse	Lecture - Neuromuscular Transmissions and Their Disorders
	14/9/2018	13	WW G6/G7 WW G16/G17	Brettle/Feather/Kokkinos/Goyette	Tutorial - Metabolic Bone Diseases
	14/9/2018	14	WW G6/G7	Tedla / Brettle/Feather/Kokkinos/ Goyette	Practical - Clinico-Pathological Correlations of Metabolic Bone Diseases
9	18/9/2018	11	LG02	Polly/ Herbert	Evidence-based symposium
	18/9/2018	11	Pioneer Th	Tedla/ Di-Girolamo	Evidence-based symposium
	19/9/2018	12	LG02	Polly/ Herbert	Evidence-based symposium
	19/9/2018	12	Pioneer Th	Tedla/ Di-Girolamo	Evidence-based symposium
	21/9/2018	13	Mathews ThD Pioneer Th	Polly/ Herbert Tedla/ Di-Girolamo	Evidence-based symposium Evidence-based symposium
21/9/2018	14	Mathews ThD Pioneer Th	Polly/ Herbert Tedla/ Di-Girolamo	Evidence-based symposium Evidence-based symposium	
Midsession Break					
10	02/10/2018	11	LG02	Polly	Lecture - Pathological Basis of Neuromuscular Diseases
	03/10/2018	12	LG02	Birznieks	Lecture - Pathological Basis of Upper and Lower Motor Neuron
	05/10/2018	13	WW G6/G7	Polly/ Brettle/Feather/Kokkinos	Combined Tutorial and Practical - Muscle Diseases
	09/10/2018	11	LG02	Tedla	Lecture - Head Injury and Intracranial Haemorrhages
10/10/2018	12	LG02	Velan	Lecture - Pathogenesis of Shock	
12/10/2018	13	WW G6/G7	Tedla/ Brettle/Feather/Kokkinos/ Goyette	Combined Tutorial and Practical –Intracranial haemorrhages and shock	
12	16/10/2018	11	LG02	Tedla	Lecture - Clinical Approaches to the Diagnosis of Peripheral Neuropathies
	17/10/2018	12	LG02	Bowring	Lecture - Rehabilitation of Neuro-Musculoskeletal Diseases
	19/10/2018	13	WW G6/G7	Tedla	Revision - Briefing on end of the year practical and written exams and feedback on homework tasks
19/10/2018	14	WW G6/G7	Tedla/ Brettle/Feather/Kokkinos/ Goyette	Q&A session about the course	
13	26/10/2018	13	WW G6/G7	Tedla Brettle/Feather/Kokkinos	Practical Examination

NOTE: Any changes in timetable will be announced on Moodle at <https://moodle.telt.unsw.edu.au/>

*Indicated lectures might not be recorded due to patient confidentiality and intellectual property issues.

Lecture Program Outline

Lecture Title	Lecturer	Content outline
Revision of bone, joint and skeletal muscle histology	PD	Types of bones, joints & cartilage; histology of synovial joint; micro architecture and histology of bones
Pathological bases of bone/joint pain and limitation of movement	NT	Cause overview, aetiology, pathogenesis and diagnosis of bone and joint pain
Causes of fractures and mechanisms of fracture healing	NT	Types of fractures, determinants of traumatic fracture healing and assessment of bone healing
Treatment and complications of fractures	NT	Principles of treatment and Complications of fractures
Prelude to evidence-based symposium	NT	Introduction to the protocols and guidelines of the symposium, selection of topics and outline of timetable.
Differential diagnosis of back pain	CR	Aetiology and pathogenesis back pain: intervertebral disc diseases, degenerative, and inflammatory joint diseases and non-skeletal causes of back pain.
Primary bone tumours	KB	Types of bone tumours, macro and microscopic features, clinical features and complications
Metastatic bone tumours	KB	Metastases to bone; sources of metastases, histopathological features; Involvement of the bone in haematological malignancies
Causes, clinical manifestation and diagnosis of poly-arthropathies	SO	Polyarthritis with special emphasis on aetiology, pathogenesis, clinical features, diagnosis and complications of rheumatoid arthritis, and brief outline of spondyloarthropathy and mixed connective tissue diseases as relevant differential diagnoses
Causes, clinical manifestation and diagnosis of mono- and oligo-arthropathies	KTB	Mono/oligo-arthropathies: causes; pathogenesis and clinical features of osteoarthritis, crystal arthropathies and septic arthritis
Diagnostic imaging of musculoskeletal diseases	SM	An outline of types of imaging techniques available for musculoskeletal diseases and their indications, cost, advantages and disadvantages
New approaches to musculoskeletal repair	CM	Summary on a cutting-edge research on new approaches in treatment of musculoskeletal damages
Strains, sprains and dislocations	ID	Evaluation of muscle, tendon, ligament and meniscus injuries with special emphasis to shoulder and elbow dislocation and knee and ankle injuries.
Forensic pathology of musculoskeletal system	JD	Medico-legal relevance of investigation of death; Comparisons of coronial and hospital autopsy; Forensic investigation of musculoskeletal injuries
Metabolic bone disease	MW	Classification; macroscopic, microscopic, radiological and clinical features; complications
Neuromuscular transmissions and their disorders	AM	Structures of neuromuscular junctions, processes of neuromuscular transmission and pathophysiology of common neuromuscular disorders
Pathological basis of neuromuscular diseases	PP	Histopathological features of myopathy, myasthenia disorders, and neurogenic disorders resulting in muscle disease; investigation of muscle diseases and indications for muscle biopsy.
Upper and lower motor neuron lesions	IB	Pathological basis of UMN and LMN lesions, clinical manifestations and underlying aetiology
Head injury and intracranial haemorrhages	NT	Intracranial haemorrhage-epidural, subdural, subarachnoid, intracerebral: causes and effects
Pathogenesis of shock	GV	Pathophysiology, causes and effects of shock
Clinical approaches to peripheral neuropathy	NT	Pathological responses to peripheral nerve injury and clinical assessments
Rehabilitation of neuro-musculoskeletal diseases	GB	Outline indications, general approaches of rehabilitation programs in Neuro-musculo-skeletal diseases and discuss cost

KEY:

Birznieks	Dr Ingvar Birznieks	Senior lecturer, SOMS, Department of Physiology, UNSW
Bowring	Dr Greg Bowring	Senior lecturer, FAFRM (RACP), UNSW; Staff Specialist, POWH
Bryant	Dr Katherine Bryant	Senior lecturer, SOMS, Department of Pathology, UNSW
Buckland	A/Prof Michael Buckland	MBBS PhD FRCPA, Head Neuropathology, Royal Prince Alfred Hospital, Syd U
Burkhardt	Dr Karim Burkhardt	Lecturer, SOMS, Department of Pathology, UNSW
Dedova	Dr Irina Dedova	Senior lecturer, SOMS, Department of Anatomy, UNSW
de-Permentier	Mr Patrick de-Permentier	Lecturer, SOMS, Department of Anatomy, UNSW
Di Girolamo	Prof Nick Di Girolamo	Professor, SOMS, Department of Pathology, UNSW
Duflo	Prof Johans Duflo	Consulting Forensic Pathologist, Professor, Syd U, UNSW
Herbert	Dr Cristan Herbert	Senior lecturer, SOMS, Department of Pathology, UNSW
McFarland	A/Prof Clive McFarland	A/Professor, Graduate School of Biomedical Engineering, UNSW
Moorhouse	A/Prof Andrew Moorhouse	A/Professor, SOMS, Department of Physiology, UNSW
Morris	Dr Sarah Morris	Senior lecturer, Department of Radiology, POWH
O'Neill	Dr Sean O'Neill	Senior lecturer, SWAHS, Liverpool Hospital, UNSW
Polly	A/Prof Patsie Polly	A/Professor, Department of Pathology, UNSW
Rodrigo	Dr Chaturaka Rodrigo	Lecturer, Department of Pathology, UNSW
Sunderland	Dr Annie Sunderland	Conjoint lecturer, Prince of Wales Hospital, Department of Rehabilitation
Tedla	A/Prof Nicodemus Tedla	A/Professor, Department of Pathology, UNSW
Truchini	Dr John Truchini	Lecturer, MBBS, FRCPA, Department of Pathology, Syd U
Velan	Prof Gary Velan	A/Professor, SOMS, Department of Pathology, UNSW
Weber	Dr Martin Weber	Senior lecturer, MBBS, FRCPA, Department of Pathology, UNSW

Guide to Practical Classes

Practical classes and tutorials in Musculoskeletal Diseases are aimed at amplifying and extending your understanding of the topics gleaned from attendance at lectures and reading of the recommended text, as well as correcting any misconceptions. Hence, adequate preparation and active participation are essential.

Practical classes will reinforce the clinico-pathological correlations involved with each topic. They are intended to help you to acquire the ability to recognize the macroscopic and microscopic features of pathology specimens and to relate the pathology to clinical application. The format of each practical class will be at the discretion of the tutor. Macroscopic “pots” will be generally used in conjunction with projected microscopic slides, x-rays and other materials. Materials for the practical classes are located at UNSW Virtual slides in Moodle by logging in to <https://moodle.telt.unsw.edu.au> Remember, it is much better to make a mistake in the relative safety of a practical class, than to make a critical error in an essay or exam because of misconception of basic pathological principles. ***It is recommended that you regularly visit the Museum of Human Disease.***

A simple guide to description of macroscopic specimens (“pots”)

The best approach to the study of macroscopic specimens in the Museum is to be systematic. As you cover each lecture topic this year, you should make it a point to visit the Museum to become familiar with macroscopic examples of that disease process, and other related conditions. One of the major tasks for you will be to learn how to differentiate with the naked eye between disease processes that at first glance have similar appearances. Sometimes this cannot be accomplished even by close examination, in which case you should formulate a list of differential diagnoses, in order of decreasing likelihood. All this takes time and careful attention to honing your skills of observation in the Museum. **In addition to the specimens and related conditions covered during practical classes, you are expected to cover all specimens in Bay 6, Bay 13, Bay 17 and Bay 21 of the Museum of Human disease.**

1) Anatomical description

Almost all macroscopic specimens will contain sufficient “normal” tissue for you to identify the organ(s) of origin. Hence a good appreciation of normal anatomy is required (i.e. pathology requires integration with your previous studies). Knowledge of the normal dimensions of organs is important in order to comment on pathological enlargement, distortion or shrinkage of tissue. The way in which the tissue has been mounted is also relevant. For example, bones are usually kept intact or cut longitudinally to display abnormalities in the bone marrow and medulla.

2) Description of the lesion(s)

A “lesion” is a recognisable abnormality in an organ or tissue caused by injury or disease. Lesions can be sub-classified into “focal” (localised), “multifocal” and “diffuse” (an abnormality of the entire organ or tissue). An example of a focal lesion is a tumour in the lower part of femur. You should describe focal lesions as you would describe a lump in a surgical patient, e.g. “There is a mass lesion 5 cm in diameter above the knee, pushing the periosteum and extending to the overlying muscle. The mass is predominantly solid and whitish in colour, with focal areas of brown-red discolouration (haemorrhage) and softening (necrosis).”

3) Identification of the major pathological process

Once you obtain a basic knowledge of the classification of disease, it is possible to categorise abnormalities in tissue as traumatic, inflammatory (acute or chronic), vascular (thrombosis, embolism, infarction, haemorrhage), disorders of growth (atrophy, hyperplasia, hypertrophy, hamartoma, neoplasia - benign or malignant, primary or metastatic), metabolic or degenerative. For example, the qualities of the bone lesion described above are typical of a primary malignant tumour - a single, abnormal, invasive mass that has overgrown the surrounding tissue, with areas of necrosis and haemorrhage (indicative of rapid growth).

4) Related lesions and complications

It is important to integrate your description with your theoretical knowledge of disease causation and complications. For example, wrinkled skin (solar elastosis) surrounding a skin cancer on the back of the hand is caused by the same agent as the tumour - ultraviolet radiation. In the above example, it is important to note whether the bone tumour has been complicated by invasion to the blood vessels and or spread to other bones (as osteosarcomas often do), because this has prognostic implications.

5) Anatomical diagnosis

The diagnosis is no longer a guessing game once you become aware of the basic pathological principles - your description justifies the selection of which pathological processes are operative, which you then relate to the anatomy and to your knowledge of the natural history of disease to formulate a tissue

diagnosis. In the above example, the diagnosis is “primary osteosarcoma of the lower femur, complicated by metastases to the vertebrae”.

Remember: Your descriptive skills will only improve with practice. It is recommended that students work through the Museum in pairs or small groups - one student is armed with a textbook, lecture notes and Museum catalogue, while the other(s) act as “the guinea pig” and are required to describe and identify the specimens. **Be warned: it is useless for you to look at a number on a specimen, refer to that number in the Museum catalogue and learn it by rote.** That is not an approach befitting thoughtful prospective professionals. It is much better to look carefully at a specimen, attempt to identify the disease process, justify your diagnosis, and only then refer to the catalogue, textbook and lecture notes. In the event that you are unable, even after referral to the text, to work out why a particular diagnosis was made, then you should ask your tutor at a convenient time.

A simple guide to writing histopathological descriptions

Haematoxylin and eosin are used for staining all routine sections, and special stains are used only to confirm or refute the presence of a particular substance in the tissue. In addition, histochemistry, immunohistochemistry and electron microscopy may be used extensively in the hospital situation to confirm a clinical diagnosis. Haematoxylin is preferentially taken up by nucleic acids and stains them blue, hence any highly cellular tissue will appear blue (basophilic). Other sources of basophilia include hyaline cartilage, calcium salts and bacterial colonies. Eosin is preferentially taken up by proteins, hence any proteinaceous tissue will appear pink (eosinophilic). Clear spaces may be caused by fat (washed out by aqueous fixatives), water or air. If you have an atlas of histology you may find it useful at these classes. We assume that you are acquainted with the normal histological appearances of human tissues - if not, revise this prior to examining the histopathology slides.

Armed with the basics outlined above, it is possible to write a histopathological description, which should possess the following components:

1) Anatomical and General Description

- **Draw a simple sketch of the main features** to remind you of these areas when you look at the screen or look down at the microscope. This can be used to clarify your description, e.g. area A in the sketch is strongly eosinophilic and is an area of haemorrhage, B is palely eosinophilic and is an area of fibrosis, etc.
- **Make a general statement that both identifies the tissue and indicates whether the lesion is focal or diffuse.** For example, "*Slide 1 is a 2 X 2 cm section of peripheral lung tissue (i.e. it contains no major bronchi) including one pleural surface that contains a focal basophilic lesion labelled area A. The surrounding normal lung tissue is labelled area B.*" Or "*Slide 2 is a section through the left ventricle measuring 2 X 1.5 cm including pericardium, myocardium and endocardium. The tissue is diffusely abnormal.*"

2) Description of the Major Lesion and Identification of the Major Pathological Process

- These elements require a thorough appreciation of the entirety of the section. Such an appreciation cannot be achieved by using only the 40X objective, which will result in failure to see the forest for the trees. Remember the following maxim: Use a low-power objective and a high-powered mind (not *vice versa*)!
- Avoid the trap of describing each abnormal feature in the order that you discover it, without any regard to its relationship to the totality of the lesion. That is, your description requires prior thought, interpretation and planning. By all means jot down your observations on scrap paper, but then order them (so as to exhibit your understanding of "the big picture"). The major pathological process (e.g. acute inflammation, malignant neoplasia) should then become obvious to the informed reader even before you have named it.

3) Identification of Related Lesions

- Sections may contain abnormalities that either share a common aetiology with or predispose to the major lesion (e.g. solar damage to dermal collagen in skin adjoining a melanoma), or else complicate the main lesion (e.g. invasion of dermal lymphatic vessels by melanoma cells). Linking of these elements requires an alert mind (which we hope you already possess) and an understanding of the natural history of disease (which you will acquire with study). Some complications are so important that it is necessary to comment on their absence (e.g. lymphatic or venous invasion by malignant neoplasms).

4) Tissue Diagnosis

- This should bring together the anatomy, major lesion and any related lesions in a concise fashion with the use of all relative descriptive adjectives (e.g. chronic osteomyelitis with multiple areas of acute inflammation and bacteria).

Team-based learning

At the commencement of this course you will be divided into four tutorial groups and each tutorial group will be subdivided into four teams, each consisting of six students. Each team will have a mixture of abilities and backgrounds. The aim of this teaching approach is to enhance your learning experience through the use of small group tutorials, team works, peer-teachings and peer-evaluations.

The role of the tutor is not to give you another lecture; but to facilitate your interactive discussions and assist you clarify some challenging concepts presented in your lectures, practical classes and/or text books. You are therefore strongly urged to make adequate preparation for these tutorials and encouraged to participate. Attendance to all of these tutorials is mandatory and is assessable.

Pre-reading will be allocated prior to each tutorial. Each tutorial will commence with a quiz (based on the pre-reading), which will first be attempted individually and the answers submitted to your tutor. At the end of the each quiz, the tutor will guide you through the answers, encourage discussion and provide clarifications regarding the challenging questions and concepts. Each tutorial will have additional team activities to be completed on a worksheet in your course manual. **Please bring your course manual to all the tutorials and practical classes.**

You will receive a maximum of **2%** towards your final course mark for each tutorial quiz. Over the course of 5 tutorials, this will contribute to **10%** of your final mark. Additionally these multiple choice questions are representative of what you should expect in your mid-session and final written exams and they will also provide your tutor and the course convener critical information on how you are progressing with the course that would allow timely remedial intervention.

The names in each tutorial group and team will be posted on Moodle at <https://moodle.telt.unsw.edu.au/>. The same teams will work together to develop presentations for the Evidence-Based Symposium.

Evidence based symposium

The evidence based symposium is a collection of group presentations on cutting-edge topics in musculoskeletal diseases. These presentations are aimed to enhance students' skills in team work, effective communication and peer-review processes in line with learning outcomes 5, 6 and 7 described in the Course Outline.

The selection of topics will take place in week 3, **Tuesday 7th of August 2018**. On this day teams will be allocated a random topic by a lottery from a pool of relevant topics.

Students will submit a 400-word Abstract by e-mail to n.tedla@unsw.edu.au in week 7, no later than 5 pm on **7th of September 2018**. This abstract will outline each team's forthcoming presentation in week 9. *Please follow the strict Abstract format outlined below.* Late submission and/or inappropriately formatted abstracts will not be accepted.

In week 9, each team of students will give a 12-minute (maximum) group presentation followed by an additional 5 minutes for question time as part of a symposium. Several one hour sessions will be set aside for students to present their work to the rest of the group. Presentation style is at the discretion of each group (examples include PowerPoint presentations, Video, YouTube, role play, interview, etc.). Groups can choose their spokesperson beforehand, although all students are expected to contribute equally and the performances of each individual may affect the group's overall score. The presentation will need to be supported by a thorough literature review. At the end of the presentation, questions can be asked of any member of the group by students and members of academic staff.

15% of the final mark for the course is allocated for this task, of which **2.5%** will be determined by members of the group, who will provide their collective score for each group member at the end of their presentation. **2.5%** will be determined by peers in the audience and **10%** will be allocated by academic staff (see assessment criteria on the following pages). Attendance at all of the presentations is mandatory. Students will lose 1% for each day they do not attend and will lose an additional 2% if they do not attend their own group presentation.

The timetable for the Evidence Based Symposium will be posted on Moodle at <https://moodle.telt.unsw.edu.au/>

Format for Evidence Based Symposium Written Abstract

Time New Roman, font 12, justified

Title and headings in Bold → **Joints Replacement - The Advances and Pitfalls of Current Research Aimed at Improving Duration** - Smith J, Kane SL, Lim K, Kwok J and Krishnan G.
School of Biomedical Engineering, University of NSW, 2052 Australia ← **Address in Italics**

Objective: The average life span for a typical joint replacement is between 10 to 12 years. The objective of this presentation is to investigate current advances and pitfalls in surgical techniques and materials used aimed at improving durability of joint replacements

Methods: Research for the presentation began by seeking council with Professor William Walsh who provided us with first hand information as well as resources, including textbooks and joint prosthetics. The other information was obtained through the UNSW Sirius application. Search engines such as Science Direct, Compendex, MEDLINE and Pub Med provided abstracts on journal articles relative to our presentation question. We selected studies published from 1966–2009 and refined our search scope using the key words joint replacement, joint arthroplasty and total hip replacement. Statistics were also obtained from the Australian Orthopaedic Association National Joint Replacement Registry.

Presentation Style: The presentation method incorporated the use of PowerPoint while utilising three different speakers. The first speaker represented the patient, who discussed the need for increased duration of replacements and outlined relevant statistical information on the subject. The second speaker is representative of the surgeon/specialist, who explained the importance of good surgical technique in prolonging duration, while demonstrating that every advance in materials or treatment appears to bring with it several disadvantages. The third speaker is the researcher who outlines the importance of material research in joint arthroplasty. The use of a PowerPoint presentation allows us to explore several examples of current research in more detail than other forms of media. It was also selected because of its reliability, ease of use and familiarity amongst group members. As part of our presentation, several replacement hip prosthetics were distributed to the audience. By having a tangible example of a replacement accessible we believed that a greater connection and understanding of the subject would be attained.

Results: Although joint replacement surgery has advanced significantly there are still major improvements and advancements needed if researchers expect to extend the duration of joint replacements. It appears that with any new breakthrough in material, fixation or treatment there are several pitfalls and disturbances that challenge surgeons and researchers assessments of what is and what is not appropriate for implantation. **Submitted by e-mail to n.tedla@unsw.edu.au**

Conclusions: There are still significant challenges and pitfalls in obtaining joint longevity primarily related to lack of suitable materials that have the desired strength, flexibility and biological properties.

Margins 2.2 cm all around

Evidence Based Symposium assessment forms

Marking scheme for team member assessment

Student Name:

Group number:

Assessors names:

	/10
Participation in the planning of the presentation	
Execution of allocated tasks effectively and on time	
Attendance to meetings called on by group members	
Contribution to group discussion	
Scientific quality of contribution	
Total	

Justification

.....

Signature:

Date:

Marking scheme for peer assessment

Presenting group:.....

Topic:

Student Assessor: Name..... Group No.

	/10
Originality of presentation	
Clear explanation of the most important aspects of topic	
Evidence of inclusion of recent medical literature	
Evidence of critical evaluation of the literature	
Answering relevant questions	
Total	

Comments:

.....

.....

.....

.....

.....

.....

.....

.....

.....

.....

.....

.....

.....

.....

.....

.....

.....

.....

.....

Signature:

Date:

Marking scheme for assessment by academic staff

Group number:

Assessor's name:

	/10
Demonstrate an understanding of the topic and how it fits into the point of discussion	
Demonstrate effective communication of the most important aspect of the topic	
Ability to effectively discuss questions on the topic	
Demonstrate an ability to utilise the current medical literature to support argument	
Clear and justified conclusions	

Comments:

.....

.....

.....

.....

.....

.....

.....

.....

.....

.....

.....

.....

.....

.....

.....

.....

.....

.....

.....

.....

.....

.....

.....

.....

.....

.....

Signature:

Date:

Adaptive tutorials

These consist of 5 online adaptive tutorials focusing on learning outcomes 1, 2, 3 and 4. These highly integrated on-line tutorials are excellent means for students to revise some of the key concepts in the course. The aim of these tutorials is to provide students with prompt feedback on their progress that will assist their preparation for the exams. They will allow independent learning and provide a guide to each student's strengths and weaknesses for a given topic. Each adaptive tutorial will be first attempted under the guidance of your tutor and will then be accessible via Moodle at <https://moodle.telt.unsw.edu.au/> throughout the course. Please use the latest version of Firefox or Internet Explorer to view microscopic virtual slides.

Assessments

Students will undertake multiple forms of assessment during the session:

- 1) **Evidence based symposium** is a group presentation that comprises **15%** of the final mark. Of the **15%** total mark, **2.5%** will be determined by members of the group, **2.5%** by peer assessment and **10%** will be allocated by academic staff on the basis of content, presentation, use of relevant literature and ability to answer questions on the topic.
- 2) **Tutorial quizzes** are **weekly** individual assessments in a form of multiple choice questions and will comprise **10%** of the final mark (**2%** for each of 5 individual quizzes). Each tutorial will commence with a quiz which will be attempted individually and the answers submitted to your tutor. The tutor will guide you through the answers, encourage discussion and provide clarifications regarding of the challenging questions and concepts. Each tutorial will have additional tasks to be completed on a worksheet in your course manual. **Please bring your course manual to all the tutorials and practical classes.** Each quiz is primarily based on the two lectures given during same week and a pre-reading that will be allocated prior to each tutorial. You are therefore strongly advised to attend and review the lectures and perform the allocated pre-reading before you come to the tutorial. The recommended pre-readings are only a guide, additional reading on the subject from the prescribed textbooks is highly recommended.
- 3) **Mid-session written exam.** Students will complete a 45minute written mid-session exam during week 6, on **Friday 31st of August 2018 at 1:00pm**. The exam consists of 5 multiple choice questions and 3 short answer questions that may include interpretation of diagnostic image(s), describing pathophysiological processes, description and diagnosis of a macroscopic specimen and/or writing histopathological reports. This will constitute **10%** of the final mark of the course. General feedback about the mid-session exam will be provided to each tutorial group during week 7, on **Friday the 7th of September 2018, 1:00-2:00pm**. Students who performed poorly in this exam may receive individual feedback either face-to-face or electronically. The aim of this assessment is to provide timely feedback on your progress and provide you with remedial assistance if needed.
- 4) **A practical examination in week 13.** Students will complete a practical exam on **Friday the 26th of October 2018, 1:00-3:00pm in room G6/G7 WW Building**. This will constitute to **20%** of the final mark for the course. The exam will consist of a series of 10 stations, each with questions based on material presented during term focused on learning outcomes 2, 3, 4 and 5 described in the Course Outline. Students will rotate around the stations, spending 4 minutes per station.
- 5) **End of course written examination.** At the end of the session there will be written exam that accounts for **45%** of the final mark for the course. The questions assess all the learning outcomes and encourage an in-depth understanding of the pathology of musculoskeletal diseases in a clinical and research context. Marks will be weighted as follows: short answer questions 25%; and objective items 20%. The short answer questions vary in style, but are intended to provide you with the opportunity to demonstrate your understanding of the topic and your ability to integrate ideas rather than simple regurgitation of facts. The objective items consist of 20 multiple choice questions where the best or most appropriate answer is chosen from the alternatives provided.

Sample Examination Paper

SAMPLE END OF COURSE EXAMINATION FORMAT FOR 2018

- (1) TIME ALLOWED: 1.5 HOURS.
- (2) ANSWER ALL QUESTIONS.
- (3) ANSWER **PART A** QUESTIONS 1 AND 2 IN SEPARATE BOOKS. WRITE LEGIBLY IN INK.
- (5) ANSWER **PART B** USING THE GENERALISED ANSWER SHEET PROVIDED.
- (6) THIS PAPER MAY NOT BE RETAINED BY THE CANDIDATE.

PART A (25 Marks)

1. Explain to a healthy 20-year-old female how she might be able to prevent herself from developing osteoporosis later in life.

(10 marks)

2. A 22-year-old man was brought by ambulance to the Emergency Department. One hour previously, he had been driving a car and was involved in a high-speed head-on collision. He had not been wearing a seat belt. Immediately after the accident, he briefly lost consciousness and recovered soon after. On arrival to the hospital he was disorientated and was gradually losing consciousness. Initial examination revealed multiple abrasions to the head, fracture on the left side of the skull and some bleeding from the left ear. What injuries might this patient have sustained? Explain how these might have developed.

(10 marks)

PART B (20 marks)

This part of the examination consists of 20 questions, each containing 5 statements. For each question, select the **BEST or MOST APPROPRIATE** answer (i.e that which is most relevant for the disease and/or its consequences) from among the alternatives, several or all of which may be true. On the supplied generalised answer sheet, **FILL IN** the corresponding circle. **USE PENCIL.**

1. Antibody tests are useful in the diagnosis of:
 - (A) Parkinson disease
 - (B) Multiple sclerosis
 - (C) Segmental demyelination
 - (D) Myasthenia gravis
 - (E) Motor neuron disease
2. Osteosarcomas:
 - (A) May arise in bones affected by Paget's disease
 - (B) Usually metastasise to local lymph nodes
 - (C) May show areas of cartilage formation
 - (D) Commonly arise in the metaphysis of long bones
 - (E) Are associated with exposure to ionising radiation
3. Intervertebral disc herniation:
 - (A) Characteristically occurs at L3/L4
 - (B) Is commonly associated with facet joint degeneration

- (C) Typically leads to spondylolisthesis
 - (D) Usually results in anterior protrusion of the nucleus pulposus
 - (E) Affects athletes more frequently than the elderly
4. Duchene muscular dystrophy:
- (A) Dystrophin is present in large quantities
 - (B) Clinical expression occurs in adolescence and progression inevitable
 - (C) It is the most common of the X-linked muscular dystrophies
 - (D) Is commonly associated abnormal muscle and nerve fibres
 - (E) Pulmonary infection is a rare complication
5. Rheumatoid Arthritis:
- (A) Is associated with periarticular osteoporosis and juxta-articular erosions
 - (B) Is characterised by a florid polymorphonuclear cell infiltrate within hyperplastic vascular synovia
 - (C) Yields chronic inflammatory cells on aspiration of synovial fluid
 - (D) Is associated with elevated serum rheumatoid factor in approximately 95% of cases
 - (E) Typically presents as a chronic, asymmetrical, joint arthropathy

Answers: 1D, 2D, 3E, 4B, 5A

Resources for Students

You are expected to use the following text available online via the UNSW library website at <http://library.unsw.edu.au> (zID and zPass required). Search for Robbins Basic Pathology. *Robbins Basic Pathology*. 10th Edition. V. Kumar, A.K. Abbas, & J.C. Aster (2018). Saunders & Co. Philadelphia PA; Elsevier Saunders. This book can also be purchased from the UNSW Book Store.

Students wishing to study the molecular biology, clinical features of diseases and diagnosis in greater depth might consider the purchase of the following texts:

1. *ROBBINS AND COTRAN, Pathologic Basis of Disease* 9th edition. V. Kumar, A.K. Abbas & J.C. Aster (2013) Elsevier Saunders. (recommended)
2. *ORTHOPAEDIC, Examination, Evaluation and Intervention*. Mark Dutton (2004). McGraw Hill.
3. *DIAGNOSTIC MUSCULOSKELETAL IMAGING*. Theodore T Miller & Mark E. Schweitzer (2005). McGraw Hill.
4. *MUSCULOSKELETAL EXAMINATION*. Jeffrey Gross, Joseph Fetto & Elaine Rosen 3rd Ed (2009). Wiley Blackwell.
5. *HISTOLOGY AND CELL BIOLOGY. AN INTRODUCTION TO PATHOLOGY*. Abraham L. Kierszenbaum. Mosby (2002).

Additional Learning Resources

In addition, there are many resources available on the web, which vary from simple patient information brochures to on-line pathology courses to information on the latest research. Some general sites you may find useful are:

Medline Plus ('health topics' index of disease with information)

<http://www.nlm.nih.gov/medlineplus/healthtopics.html>

American Arthritis Foundation (Patient information and latest research on arthritis) <http://www.arthritis.org>

National Institute of Arthritis and Musculoskeletal and Skin Diseases <http://www.niams.nih.gov/>

Neuromuscular Disease Centre, Washington University, St Louis, MO USA

<http://www.neuro.wustl.edu/neuromuscular/>

Muscle Physiology, University of California, San Diego <http://muscle.ucsd.edu>

PATH 3207 Moodle course

The online module for the Musculoskeletal Disease course can be found by logging in to Moodle at <https://moodle.telt.unsw.edu.au/>, using your student number as the user name (e.g. z1234567) and your zPass as the password. The PATH3207 Moodle module will contain information directly related to the course such as tutorial lists, revisions to the lecture timetable, examination timetables, links to lecture slides and Lecture Recording+ etc. **You are expected to visit this site regularly during your course.**

Online lecture slides

PDF version of most lecture slides will be uploaded to Moodle together with corresponding recorded lectures (Lecture Recording+). However, large numbers of lecture slides in this course are images that are not annotated but explained/discussed in during the lecture. Therefore, you are strongly advised to attend lectures in person. Note that no online recordings will be available for lectures that are of sensitive nature and those where intellectual property is protected.

PATH3207 Virtual slide box and Images

Students will be able to access microscopic slides and images to all practical classes through the UNSW Virtual slides in Moodle by logging in to <https://moodle.telt.unsw.edu.au>. Students can also log into large collections of our macroscopic and diagnostic images, available in SLICE at the BEST Network linked to <https://www.best.edu.au>.

Images of Disease (IOD) database

This database is a collection of images used for teaching within the Department. The latest version is available online, optimised for smart phones and tablet computers as well as Firefox4+, Chrome 13+ and Safari browsers on laptop and desktop computers at <http://iod.med.unsw.edu.au/> . An interactive Images of Disease app for iPhone and iPad is available to download from that website. Android and Windows phone versions will also be released shortly.

The IOD database contains over 3000 images relevant to your study as an undergraduate. Many of these images represent specimens from the Museum of Human Disease, histopathological images from the student histopathological slide set as well as some diagnostic images such as X-rays.

Many images used in this program are of a sensitive nature, and are intended for the purpose of private study by pathology students and graduates. You should exercise appropriate standard of professional ethics when using them.

Interactive images of disease

This is a collection of “hotspotted” images from the Department of Pathology’s database on the Museum of Human Disease web page. Images contain clickable “hotspots” allow identification of the normal features and pathological changes within each specimen. At present this is limited selection, intended for the education of senior high school students and interested members of the public. However, these might be useful tools for you to practice your skills in interpreting macroscopic specimens.

The Museum of Human Disease

The Donald Wilhelm Museum of Human Disease is located on the ground floor of the Samuels Building (Building F25). It was established by Professor Donald Wilhelm, the Foundation Professor of Pathology at this university. Thanks to his foresight, and to the tireless efforts of Dr G. Higgins (the Museum Curator until 2004), the Museum has been meticulously maintained and updated over the years to reflect the changing patterns of disease in our society. The Museum contains over 2,700 specimens (or “pots”), which display diseased human tissue at the macroscopic level, usually preserved in formalin. Specimens are obtained both from organs removed surgically and from tissue obtained at autopsy, where the natural history of disease is in full view. **Please take note that some specimens of diseases which have become rare, e.g. diphtheria, are over 60 years old, and are irreplaceable.** Each specimen is numbered and is accompanied by a clinical history (when known), a macroscopic description of the abnormalities displayed, and a histopathological description of changes at the microscopic level (where relevant). That information, specific to each of thirty areas (or “bays”), can be found in the Museum catalogues located in a bracket within each bay.

All the specimens in the museum are arranged in one or other of two major groups. One group comprises collections of specimens according to pathological processes such as congenital, inflammation and healing, vascular, neoplasia etc. The second group comprises collections of specimens under organ systems, such as cardiovascular, central nervous, renal etc. As responsible adults, we expect you to maintain decorum in the museum behave with care and respect for the integrity of the specimens, and help to keep the Museum tidy at all times. This means no eating or drinking in the Museum, and always returning specimens and catalogues to their allocated places. **Do not shake the pots!** This activity conveys no useful information, but often damages the specimens. If you discover that a specimen is leaking or broken, follow the instructions listed in the safety notice below. **Remember that the Museum is a precious learning resource, of which you are encouraged to make full use.**

The Museum of Human Disease page contains links to some excellent undergraduate and postgraduate educational resources that might be useful for you. The address is <https://medicalsciences.med.unsw.edu.au/community/museum-human-disease/education>

Security in the Museum

It is a crime under the Human Tissue Act to steal or mistreat material preserved in the Museum or practical class laboratories. Anyone who contravenes the Act will be prosecuted.

In order to protect the collection of specimens, access to the Museum is restricted for students during weekdays from 9 a.m. to 5 p.m. The Museum is security locked, and can only be entered by using your student card to enable the doors to be opened. Mr Derek Williamson, Mr Dean Lovett and Mr Adam Austin play a supervisory role during office hours. The Museum and practical class laboratories are under constant electronic surveillance.

Safety in the Museum

- Always handle museum specimens with care and respect. All specimens consist of generously donated human tissue.
- The specimens are preserved in Perspex and contain a range of preserving chemicals that may be harmful. Chemicals used may include formalin, pyridine and sodium dithionate. A full list of chemicals and associated information is available at the Health and Safety (H&S) station in the Museum and on the SoMS website.

Chemical	Max. Percentage Composition
Glycerol	17 (v/v)
Pyridine	0.8 (v/v)
Sodium Acetate	7 (w/v)
Formalin	<2 (v/v)
Sodium Dithionate	0.4 (w/v)

- For reasons of hygiene, never take food or drink into the museum.
- Never leave a museum specimen on the floor, or in any precarious position.
- If a specimen is leaking, turn it upside down to prevent further leakage, then immediately inform Mr David Cutting or a member of academic staff.
- If a specimen is broken, do not attempt to wipe up the spillage. Use the kitty litter provided in the central cupboards to absorb the fumes, then clear the area and immediately inform the Museum staff including Mr Derek Williamson, Mr Dean Lovett, Mr Adam Austin or any academic staff from the Department of Pathology.
- Remember that the museum is here for your benefit - your cooperation in maintaining neatness and safety at all times is appreciated.
- For more information on matters related to occupational and health safety policies of the UNSW visit the following web site: <http://www.ohs.unsw.edu.au/> or safety.unsw.edu.au/

Administrative Matters

You may also meet the following members of the School support staff during the course of the year:

Ms Nadia Ghafoorzada

Position: Education Support Team Leader, School of Medical Sciences

Location: Level 2 West, Wallace Wurth Building, room 264

Phone: 9385 2464

E-mail: n.ghafoorzada@unsw.edu.au

Ms Ghafoorzada is responsible for assistance with general enquiries, enrolment procedures and collection of assignments, special consideration and course timetable.

Mr Dylan Lewis

Position: Student Administrative Officer, School of Medical Sciences

Location: Level 2 West, Wallace Wurth Building, room 260

Mr Lewis is responsible for assistance with general enquiries, enrolment procedures and collection of assignments, special consideration and course timetable.

Phone: 9385 8301

E-mail: d.lewis@unsw.edu.au

Ms Catherine Yang

Position: Education Support Administrator, School of Medical Sciences

Location: Level 2 West, Wallace Wurth Building, room 260

Phone: 9385 9087

E-mail: catherine.yang@unsw.edu.au

Ms Yang is responsible for assistance with general enquiries, enrolment procedures and collection of assignments, special consideration and course timetable.

Mr Derek Williamson

Position: Manager, Museum of Human Disease

Location: Room G04 Ground Floor Samuels Building, Building F25

Mr Williamson provides support for all undergraduate teaching programs. He plays a major role in broadening the use of the Museum of Human Disease by introducing an integrated learning program for senior high school students and community interest groups. Mr Williamson Co-ordinates a network of volunteers, who assist with the supervision of visitors from outside the University.

Phone: 9385 2190

E-mail: derek.williamson@unsw.edu.au

Mr Dean Lovett

Position: Education Support Officer, Museum of Human Disease

Location: Room G06 Ground Floor Samuels Building, Building F25

Mr Lovett is Education Support Officer. Mr Lovett will assist you on how to handle if you encounter incidence of broken, leaking or displaced specimens and any museum related enquires.

Phone: 9385 1522

E-mail: d.lovett@unsw.edu.au

Mr Adam Austin

Position: Curator & Education Officer, Museum of Human Disease

Location: Room G06 Ground Floor Samuels Building, Building F25

Mr Austin is a Curator & Education Officer. Mr Austin will assist you on how to handle if you encounter incidence of broken, leaking or displaced specimens and any museum related enquires.

Phone: 9385 1522

E-mail: a.austin@unsw.edu.au

Academic Honesty and Plagiarism

The Department of Pathology considers plagiarism in submitted written work as a serious academic misconduct and imposes severe penalties. Submitted abstract, papers and/or manuscripts will be routinely checked for editorial originality using UNSW approved software called [iThenticate](#). It is therefore, advisable for students to check their papers prior to submission and confirm no professional and/or scholarly plagiarism is committed.

Evidence of plagiarism in submitted assignments, etc. will be thoroughly investigated and may be penalised by the award of a score of zero for the assessable work. Flagrant plagiarism will be directly referred to the Division of the Registrar for disciplinary action under UNSW rules.

<https://student.unsw.edu.au/conduct>
student.unsw.edu.au/plagiarism

Your attention is drawn to the following extract from the above website:

“The basic principles are that you should not attempt to pass off the work of another person as your own, and it should be possible for a reader to check the information and ideas that you have used by going to the original source material. Acknowledgment should be sufficiently accurate to enable the source to be located speedily”. If you are unsure about this consult your lecturer.

The following are some examples of breaches of these principles:

- a) Quotation without the use of quotation marks. It is a serious breach of these rules to quote another’s work without using quotation marks, even if one then refers to the quoted source. The fact that it is quoted must be acknowledged in your work.
- b) Significant paraphrasing, e.g. several sentences, or one very important sentence, which in wording are very similar to the source. This applies even if the source is mentioned, unless there is also due acknowledgment of the fact that the source has been paraphrased.
- c) Unacknowledged use of information or ideas, unless such information or ideas are commonplace.
- d) Citing sources (e.g. texts) which you have not read, without acknowledging the ‘secondary’ source from which knowledge of them has been obtained.

These principles apply to both text and footnotes of sources. They also apply to sources such as teaching materials, and to any work by any student (including the student submitting the work) which has been or will be otherwise submitted for assessment. You must obtain the prior approval of your lecturer if you wish to submit to that lecturer an essay substantially similar to one which has already been, or will be, submitted to another lecturer.

Using the principles mentioned above about proper acknowledgment, you should also proceed on the general assumption that any work to be submitted for assessment should in fact be your own work. It ought not be the result of collaboration.”

Appropriate citation of sources therefore includes surrounding any directly quoted text with quotation marks, with block indentation for larger segments of directly-quoted text. The preferred format for citation of references is an author-date format with an alphabetically arranged bibliography at the end of the assignment. Note that merely citing textbooks or website URLs is unlikely to yield a bibliography of satisfactory standard. ***The internet should be avoided as a primary source of information.*** Inclusion of appropriate journal articles, both primary research publications and reviews, is usually expected.

Student Equity and Disabilities Unit

Students who have a disability that requires some adjustment in their learning and teaching environment are encouraged to discuss their study needs with the course convener prior to or at the commencement of the course. Alternatively contact the Student Equity Officer (Disability) in the Student Equity and Disabilities Unit (9385 4734). Information for students with disabilities is available at: <http://www.studentequity.unsw.edu.au>

Issues that can be discussed may include access to materials, signers or note-takers, the provision of services and additional examination and assessment arrangements. Early notification is essential to enable any necessary adjustments to be made.

Teaching Laboratories Risk Assessments

Medicine Teaching Laboratory Student Risk Assessment		Pathology practicals in G6/G7 & G08 & G16/G17 at Wallace Wurth for PATH3207, 2018
---	---	---

Hazards	Risks	Controls
Ergonomics	Musculoskeletal pain	Correct workstation set-up.
Electrical	Electrical shock/fire	Check electrical equipment in good condition before use. All portable electrical equipment tested and tagged.
Handling pots	Chemical spillage	Instructions on correct manual handling of pots

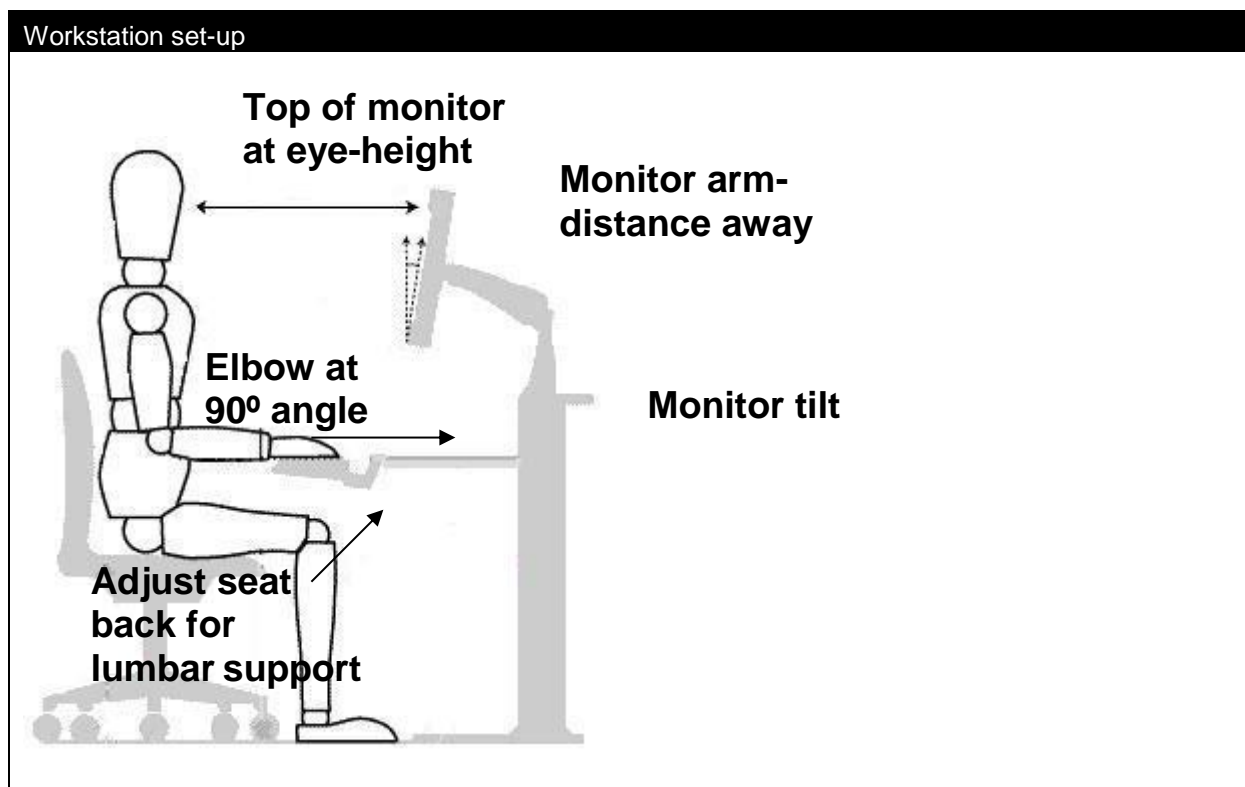

Personal Protective Equipment
<p>All pots contain real human tissue that has been generously donated to medical science and must be treated with appropriate respect and dignity. Specimens are preserved in Perspex and contain a range of preserving chemicals that may be harmful. Chemicals used include formalin, pyridine, sodium dithionate. A full list of chemicals and associated MSDS information is available in the H&S Station and on the SoMS website.</p> <p>MANUAL HANDLING OF POTS It is recommended that all students wash their hands thoroughly as they leave practical class. Chemical residues may be present on pots. Carry one pot at a time. Use two hands at ALL TIMES and support the base of pot. Avoid rough handling and/or tilting of pots. This can cause leaking joints or tear tissue in specimen. Limit the number of pots on a table at any one time.</p>
SPILLS AND LEAKAGES

If a specimen is leaking or broken, do not attempt to wipe up the spillage. Clear the area and immediately inform the Museum Manager or a member of academic staff. A spill kit will then be used to absorb the fumes.

Emergency Procedures

In the event of an alarm, follow the instructions of the demonstrator. The initial sound is advising you to prepare for evacuation and during this time start packing up your things. The second sound gives instruction to leave. The Wallace Wurth assembly point is in the lawn in front of the Chancellery. In the event of an injury inform the demonstrator. First aiders and contact details are on display by the lifts. There is a first aid kit in the laboratory and the Wallace Wurth security office.

Clean up and waste disposal

Not necessary in these practicals.
No open-toe shoes allowed

Declaration

I have read and understand the safety requirements for this practical class and I will observe these requirements.

Signature:.....Date:.....

Student Number:.....

Reviewed on 04/07/2018

Hazards	Risks	Controls
Physical Sharp plastic	'Stabbing' wound of hand	<ul style="list-style-type: none"> Use disposable gloves Do not eat, drink or smoke in the teaching laboratory Use disposable gloves Low concentrations of chemicals used Use disposable gloves
Biological Antibody	Inoculation/Irritant	
Chemical Acrylamide	Corrosive/Flammable Irritant/neurotoxic	
Azide ...PBS	Irritant Mild Irritant	

Pipetting ergonomics: to avoid aches and pain due to repetitive pipetting follow the following guides

- Adjust your chair or stool so that your elbow is at a 90° angle while pipetting.
- Adjust the height and position of sample holders, solution container, and waste receptacle so that they are all approximately the same.
- Try to work with your hands below shoulder height.
- Let go of the pipette from time to time and give the fingers/hand a break
- Do not twist or rotate your wrist while pipetting; Use minimal pressure while pipetting
- Try to switch periodically between different types of work.

For more information on preventing repetitive strain while pipetting clicks on <https://www.anachem.co.uk/Protect-Yourself-from-RSI>

Personal Protective Equipment required			
 Closed in Footwear	 Lab. Coat optional	 Gloves	 Safety Goggles optional

Emergency Procedures
 In the event of an alarm sounding, stop the practical class and wait for confirmation to evacuate from demonstrators. Then wash your hands and pack up your bags.
 Follow the instructions of the demonstrators regarding exits and assembly points.

Clean up and waste disposal

- Remove your gloves and dispose in the biowaste bins provided.
- Dispose of all pipette tips in the bin provided.

Ethics Approval
 This type of practical does not require ethics approval.

Declaration
 I have read and understand the safety requirements for this practical class and I will observe these requirements.
 Signature:.....Date:.....